

OWNER'S MANUAL

for

FOOTWORKS[™] Faucet Controller

*Foot Operated Faucet Control Valves
for Commercial Sinks*

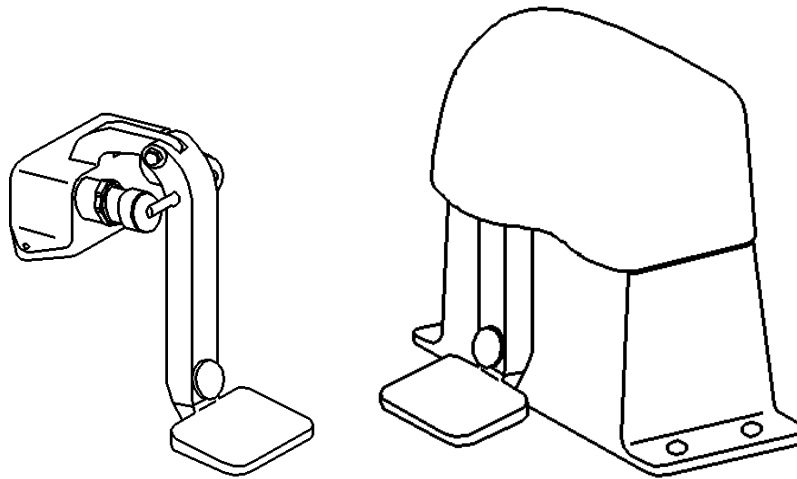

Introduction

Congratulations on your purchase of a FOOTWORKS™ Faucet Controller, an engineered pedal valve system that provides:

The Cleanest, Fastest and Most Efficient Way to Operate a Sink.

These pedal operated valves are produced using the finest heavy weight materials to provide years of dependable service in the toughest of applications. There are models for use on each and every type of sink and usually can be installed in about an hour.

The primary benefits to this technology are:

1. ***Cleanest and Safest Way to Use a Sink*** - A FOOTWORKS is a piece of equipment used to activate water flow to the sink by stepping on a pedal. The bacteria and mess that unavoidably gets on hands can be safely washed down the drain without touching the faucet. This keeps the faucets clean and germ free, solving the problem known as faucet cross contamination; a safety problem whereby clean hands become contaminated by turning faucets knobs that have been contaminated with germs from the hands of any previous sink user.
2. ***Fastest Way to Operate a Sink*** - Activating the pedal of a FOOTWORKS is a hands free way to use the sink. Users can work at and around the sink with both hands full and never have to put things down to turn the water on and off; saving time and improving work flow.
3. ***Most Efficient Way to Use a Sink*** - FOOTWORKS is a tool designed to help people use utilities efficiently. Without it, the water is sometimes left running because our hands are too busy to keep turning the water off and on. With this tool, it's easy to use the water efficiently and stop leaving the water running unnecessarily. Lower water bills, hot water energy bills, and lower sewage bills are the result. Savings range from several hundred dollars per year to as much as \$3000 per year per sink.

Table of Contents

Introduction	Page 2
Technical Description	Page 3
Installation Procedures	Page 3
Operating Instructions	Page 8
Maintenance Information	Page 11
Warranty	Page 13

Technical Description

A FOOTWORKS™ Faucet Controller is a pedal operated control valve for use on potable water. It controls the flow of both hot and cold water to a standard faucet.

It consists of a valve body, two identical push button type cartridges, and a single pedal that contacts both cartridges at the same time. A wall down the middle of the body separates the hot and cold sides of the valve. The hot and cold water do not mix in the body. The mix is set with the faucet.

The faucet control valve is connected in series with the faucet. Hot and cold water supplies are connected to the inlet ports on the body. The outlet ports are connected to the faucet.

When the pedal is pressed, the cartridges are pushed open allowing water to flow through the body and up to the faucet. The faucet generally stays in an open position at any desired temperature and flow rate setting. The user can adjust this default setting at any time by turning the faucet handles.

Depending on the model ordered, the pedal may be equipped with a latch mechanism. It is engaged by pushing the circular button just above the bottom of the pedal. When latched, the pedal stays in the depressed position providing continuous flow. The latch is released by pushing the pedal once again.

Installation Procedures

On the pages that follow are the installation procedures for each of the of FOOTWORKS™ Faucet Controller models. Review each of the following sections: *Package Contents, Tools Needed, General Procedures and the Model Specific Procedures.*

Package Contents

A Packing List is included in each box. Compare this list to the actual contents to see that no parts are missing. If installation supplies were ordered, these would be included in the box. If not the supplies can be obtained from most plumbing supply stores. If missing anything call 1-985-785-9997.

Tools Needed, Cabinet Mounted Models

- Electric Drill, with ¼" standard, and 9/16" paddle bits
- Jig Saw and/or a key hole saw
- Phillips and Flat Head Screw Driver
- Midget tubing cutters
- Open end wrenches 7/16 thru 15/16"
- Crescent wrench
- Channel locks
- Flashlight
- Lineman's pliers or heavy cutting pliers
- Towel to wipe up any water spills

Tools Needed, Floor Mounted Models

- Hiltie drill with 1/2" concrete bit
- Hammer
- Center Punch
- Phillips Head Screw Driver
- Midget tubing cutters
- Open end wrenches 7/16 thru 15/16"
- Crescent wrench
- Channel locks
- Flashlight
- Cutting pliers
- Towel to wipe up any water spills

General Installation Procedures

STEP ONE: Install the connectors for the back of the valve.

Locate the four brass fittings that screw into the back of the valve. They have 3/8" male pipe threads on one side and either 3/8" compression or 1/2" compression threads on the other. Install 7 wraps of Teflon tape in the clockwise direction on the 3/8" male pipe threads.

Note:

If installing a floor mount model, remove the top housing.
2 - 7/16" bolts on the back of the housing are to be removed.

If installing a prison grade model, remove all security screws around the edge of the top housing.

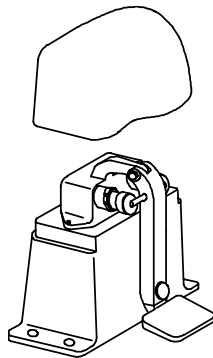

Figure 1

Screw the four brass fittings into the four ports on the back of the valve body, and tighten securely with an 11/16" wrench. A deep well socket works best.

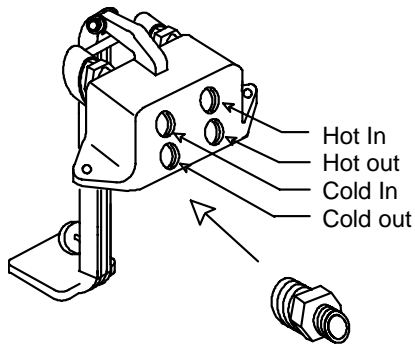

Figure 2

STEP TWO: Connect the Flex lines to the supplies and faucet

It is generally easier to install the 4 flex lines before the pedal valve is installed under the sink, so we recommend you start with this step.

Refer to figures 3, 4, 5, or 6 below, examine the flex lines and connectors included with the unit, and plan your tie in points.

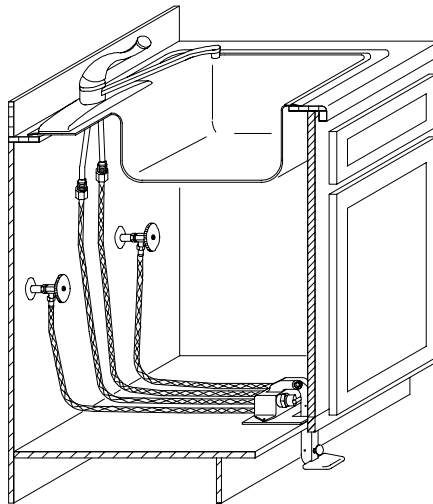

Figure 3

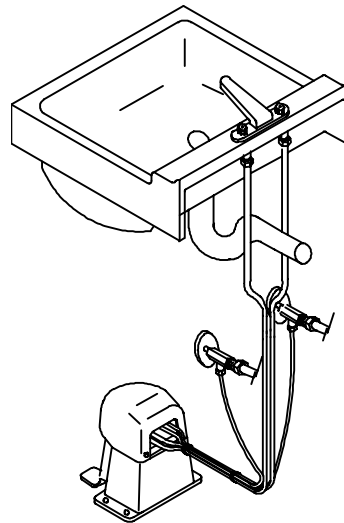

Figure 4

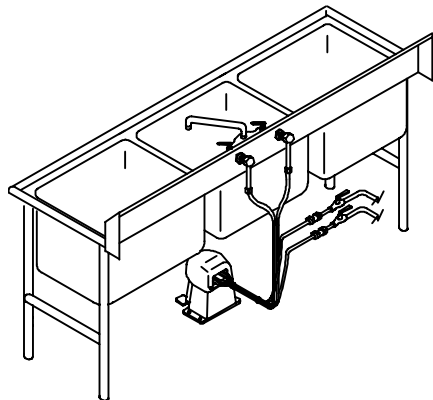

Figure 5

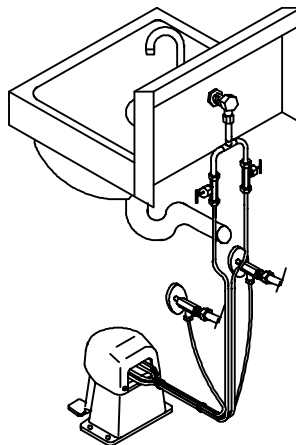

Figure 6

As you examine the figures you can see that the faucet controller is simply installed in series just before the faucet. Two flex lines go down from the supplies to the valve body. Two other flex lines go up to the faucet.

Flex lines of various lengths and brass adapters of various sizes have been included to match the needs of this specific application.

Close the supply stops before you begin work.

When possible, connect the flex lines directly to the supply stops and the faucet. We recommend you rotate the stop valve outlet to the inside or down when possible. Using the appropriate ends of the flex lines install and tighten the connecting nuts. Tighten these just snug as they have a rubber seal in the end. Over tightening will damage the connection.

In some retrofit and new construction situations, brass adapters may be needed to make the connections to the water lines. If specified, these would be included in the box. 3/8", 1/2" or 5/8" compression adapters are used to tie into the water lines. Using tubing cutters, cut the lines to provide the four tie points.

Sometimes it is necessary to use additional hardware, i.e. copper pipe, and/or screwed fittings to assemble the system. These materials would not be included in the box. This is very common when doing large triple sinks. Sometimes it is necessary to remount the faucet on the sink if only the pipe is holding it in place.

If you are installing a system as shown in figure 6, install the two needle valves and tee assembly. The needle valves are used to set the temperature and flow rate for systems using a spout instead of a faucet.

After making your connections and installing the four flex lines, refer to the Valve Mounting Procedures for either cabinet mount models or floor mount models.

STEP 3A: Valve Mounting Procedures, Cabinet Mount Models

Using the template provided, layout the slot for mounting the valve. We typically recommend the valve be installed in the center or a few inches to the left or right of center.

Using a jigsaw, cut the slot.

Position the valve with pedal in the slot. Check the need for a shim under the pedal valve mounting plate. If needed, use a provided shim to elevate the pedal valve. The bottom of the pedal should be a minimum of 1/2" above the floor.

Check for sufficient clearance for the pedal to stroke back, and that no door interference occurs. Slide the pedal valve front or back as needed. If there is not sufficient stroke for the pedal, some of the toe kick can be removed and a toe kick adapter can be installed.

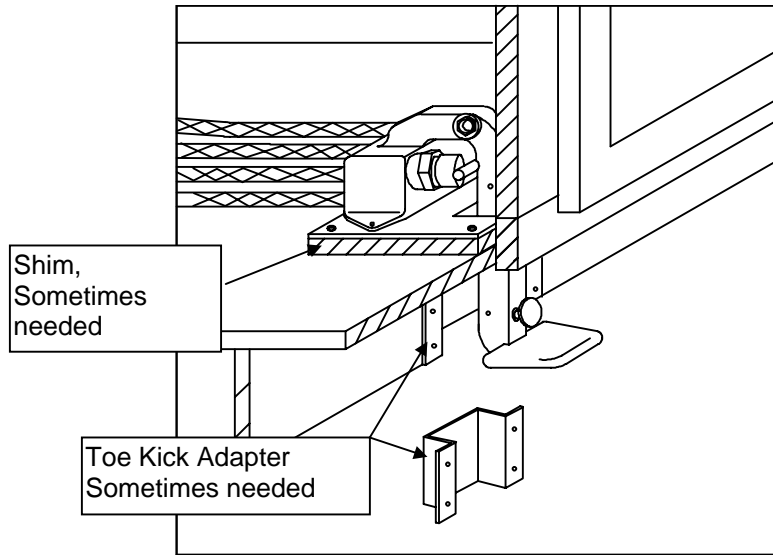

Once the position for the pedal is determined, mark the holes for the rear toggle bolts and front mounting screws.

Drill 9/16" holes for the toggle bolts and 1/4" holes for the front mounting screws.

Place the toggle bolts through the pedal valve mounting plate and any shims, and then install the toggles through the 9/16" holes.

After tightening the toggles, install the front mounting screws. Cut off the excess screw threads with the lineman pliers, or heavy cutting pliers.

Tighten the 7/16" nuts securing the body to the mounting plate.

STEP 3B: Valve Mounting Procedures, Floor Mount Models Mounting the Pedal Valve Under the Sink

Set the valve under the sink and center it relative to the faucet.

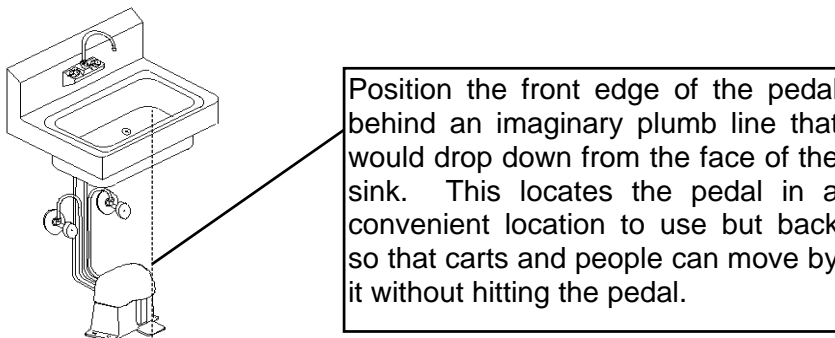

Position the front edge of the pedal behind an imaginary plumb line that would drop down from the face of the sink. This locates the pedal in a convenient location to use but back so that carts and people can move by it without hitting the pedal.

Using a pencil mark the position to drill the 4 mounting holes. Use a hammer and center punch to mark the centers of the holes. With a 1/2" Hilti drill, make the holes in the floor. 7/8" is the correct depth. Remove the dust from the holes and set the anchors. The

cone shaped part of the anchor goes in the hole first. The outer ring is driven down to expand the anchor and lock it in place.

Use the oval head stainless steel screws to secure the floor mount housing to the floor.

Installing a silicone caulk around the edge of the floor mount is recommended in kitchens.

STEP FOUR: Connect the flex lines to valve body.

Referring to figure 2 connect the flex lines to the back of the valve body. As you look from the front of the valve, hot is on the left and cold is on the right.

First connect the lines that come from the faucet to the lower connections on the body. Tighten these just snug as they have a rubber seal in the end. Over tightening will damage the connection.

Completely finish these lower connections, as you will not be able to easily reach these after the upper lines are installed.

Connect the lines that come from the supplies to the upper connections on the body. Tighten these just snug, as well.

Open the supply line valves to check operation and inspect for leaks.

After all the installation is completed and the unit has been tested and inspected for leaks, bundle the flex lines together with the included cable ties.

Doing a neat job with the flex hoses and cable ties is one of the most important parts of making a professional looking installation.

Post the “How to Operate” Sign Slightly Above The Faucet.

If you have any problems refer to the trouble shooting section.

OPERATING INSTRUCTIONS

Operating your FOOTWORKS™ Faucet Controller is simple. We do suggest you read the following instructions and show the other members of your organization how to use it.

Preset the faucet knobs to any desired temperature and pressure.

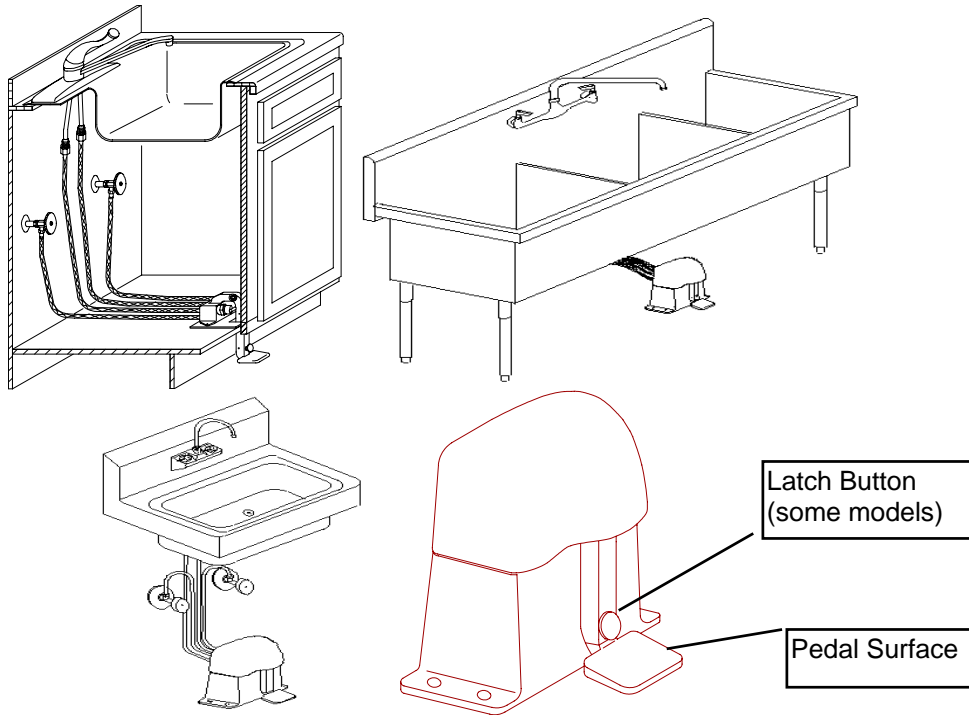

Step on the pedal surface and the water comes on.

Step off the pedal surface and the water goes off.

Some models have a latch button for continuous flow. Push the toe button in to latch the pedal in an open position. To unlatch it, step on the pedal and it automatically unlatches.

To Maximize Water Savings Benefits

When washing hands, step on pedal to wet hands.
 Step off while you lather with soap.
 Step on again to rinse.

When performing tasks at the sink, step on and off the pedal as things are placed under the spout.

Latch the pedal open only when filling the sinks, or performing another operation that truly needs continuous flow. Once you get used to stepping on and off the pedal you will find it saves you a lot of time, and conserves tremendous amounts of water.

Trouble Shooting

- Hot water flows out of the cold side of the faucet and cold water flows out of the hot water side of the faucet.

⇒ The flex lines were crossed when the hoses were connected.

- No water flows when the pedal is pressed.
 - ⇒ Both supply lines may be tied into the same side of the valve.
- Reduced flow when the pedal is pressed.
 - ⇒ Check the strainer/flow restrictor on the end of the faucet spout for partial plumage.
- Faucet runs even when pedal is not pressed.
 - ⇒ Check that the supply hoses are connected to the top connections on the back of the valve body.
 - ⇒ Pull the cartridge and check for debris caught between the end of the stem and the seal.
 - ⇒ Inspect the rubber seal on the end of the cartridge. If it is cut, a new cartridge should be installed.
- Pedal will not latch or unlatch.
 - ⇒ Cabinet Mount Models - Check for any interference with the cabinet toe kick or the floor. It may need to be routed out or cut away.

All Models - The latch hook may have gotten bent. Using pliers you can adjust the hook by bending it slightly.

Maintenance Instructions

Care for your FOOTWORKS Faucet Controller consists of periodic cleaning of the housing and the floor around the pedal. Any spray on cleaner or a soapy rag will do the job just fine.

Use of a spray lubricant every 6 months on the latch mechanism parts will keep it working smoothly. These components are in the back side of the pedal arm.

Parts Drawings

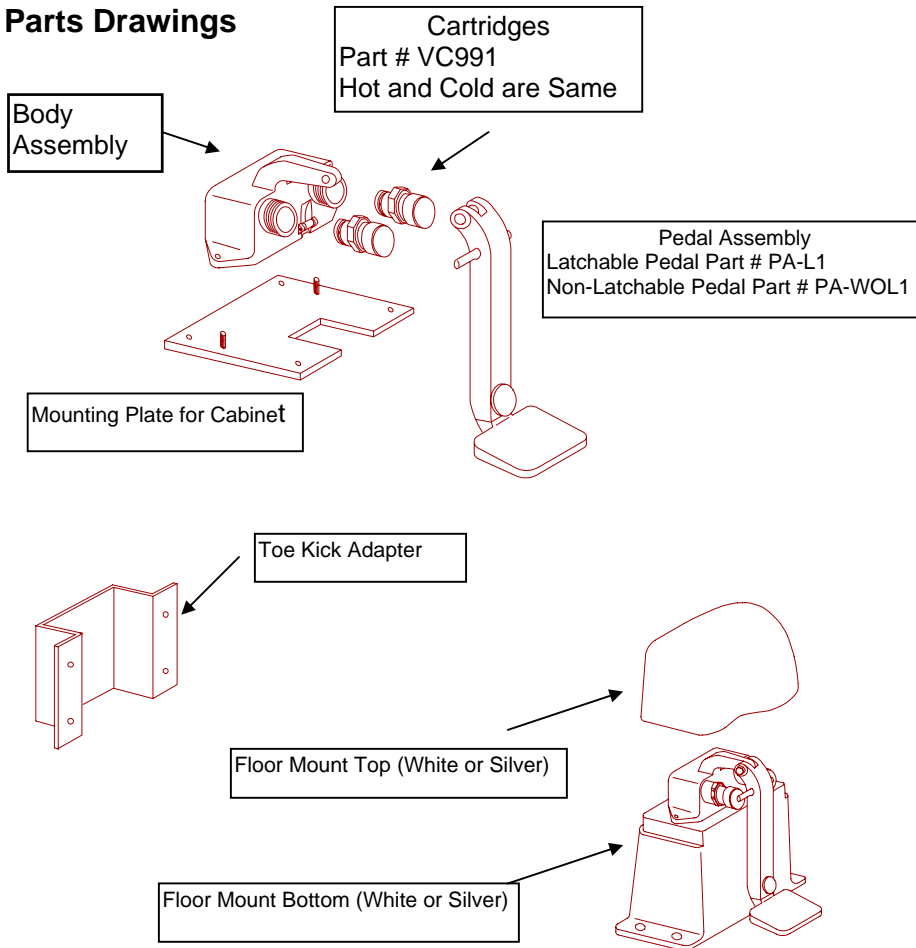

Cartridge Replacement Procedure

If you ever experience dripping from your faucet, you may need to service one or both of the cartridges.

Close off your supply stop valves at the back of the cabinet.

1. Unscrew the cartridges (A) with a 12" crescent wrench or 1- $\frac{1}{4}$ " wrench.

Inspect the end of the cartridges to see if there is any kind of debris stuck under the end of the stem. If so, you may only need to remove the debris and reinstall the cartridge.

If you find the rubber seal is damaged, you should replace the cartridge.

2. Install the new cartridge by tightening to you feel it come to a stop. You should not bear down on the wrench. There are soft rubber seals that prevent it from leaking. Over tightening will damage the cartridge or valve.
3. Check to see that bars (B) on pedal contact both cartridges at the same time. If needed, loosen the bolt on one of the bars and rotate the bar slightly to adjust. Retighten the bolt when complete.

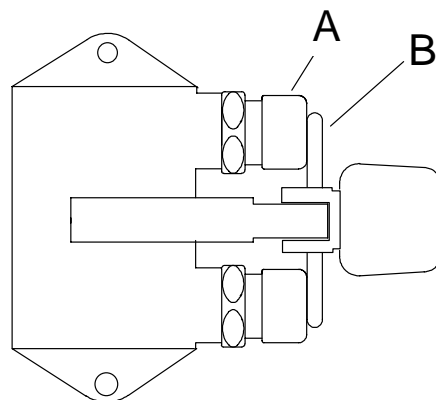
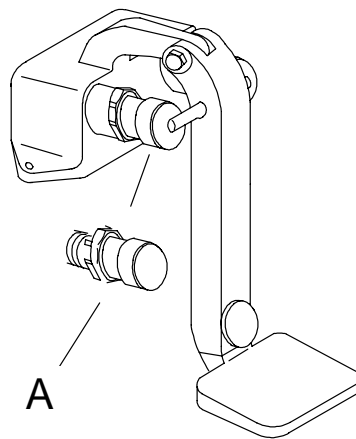

1 YEAR WARRANTY

Pedal Valves Incorporated warrants FOOTWORKS™ Faucet Controllers for one year from date of purchase.

This warranty covers defects in materials or workmanship of the FOOTWORKS™ Faucet Controller. Damage due to abuse or improper installation is not covered. On-site labor is not covered as repairs can usually be made in 10 minutes or less with telephone support from the factory. No other warranties either expressed or implied are given. Some states prohibit limitations of damages or warranties. If you live in one of these states you may have additional rights.

To obtain parts under warranty contact Pedal Valves Inc. at the number below. Proof of purchase date, (i.e. sales receipt,) is required for any warranty parts. Replacement parts will be shipped to the customer and the defective parts must be returned to Pedal Valves Inc. at the address below. Customer may send the complete unit in for warranty work, freight prepaid, if desired.

**For Assistance with Parts,
Installation, Sales, or Warranty,
Contact:**

**Pedal Valves, Inc.
13625 River Road
Luling, LA 70070**

1-985-785-9997

www.pedalvalve.com e-mail: pvi@pedalvalve.com

